

# INSTALLATION MANUAL

BMW 2.0D

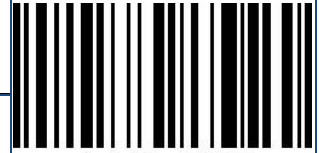

14104707

The product described in the guidance was developed, manufactured and controlled considering the necessary safety requirements. The product must be appropriately inserted around dangers for persons and things to exclude and a perfect and safe function mode to ensure. Here to have it the fitting instruction including the safety references carefully to read.

Control before the installation of the Chiptuning box the completeness of the parts belonging to the scope of supply.

## Scope of supply:

Mixes	Designation	Articel number
1x	Chiptuning Box	111064
1x	Cable loom	121133-5/24
1x	Jumper plug 24polig	13100402
1x	Cabel straps	13600004

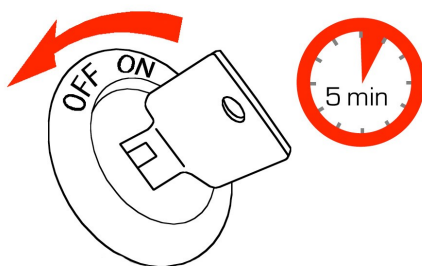

**1.**They scolded the ignition before the installation out!

**2.**Take the ignition key off!

**3.**Lock you all vehicle doors!

**4.**Do not open the vehicle doors during the installation!

**5.**Wait afterwards before the installation at least 5 minutes



In order to avoid damages at electronic vehicle components, you guarantee please before installation of electronics that you seize suitable measures for electrostatic unloading. Brew electronics absolutely water and vibration. Do not take change in the Tuning kit forwards (like an extending or a shortening of the wiring harness etc.).

# INSTALLATION MANUAL

BMW 2.0D

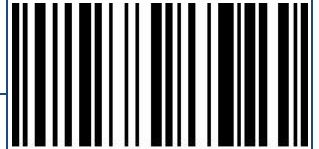

14104707

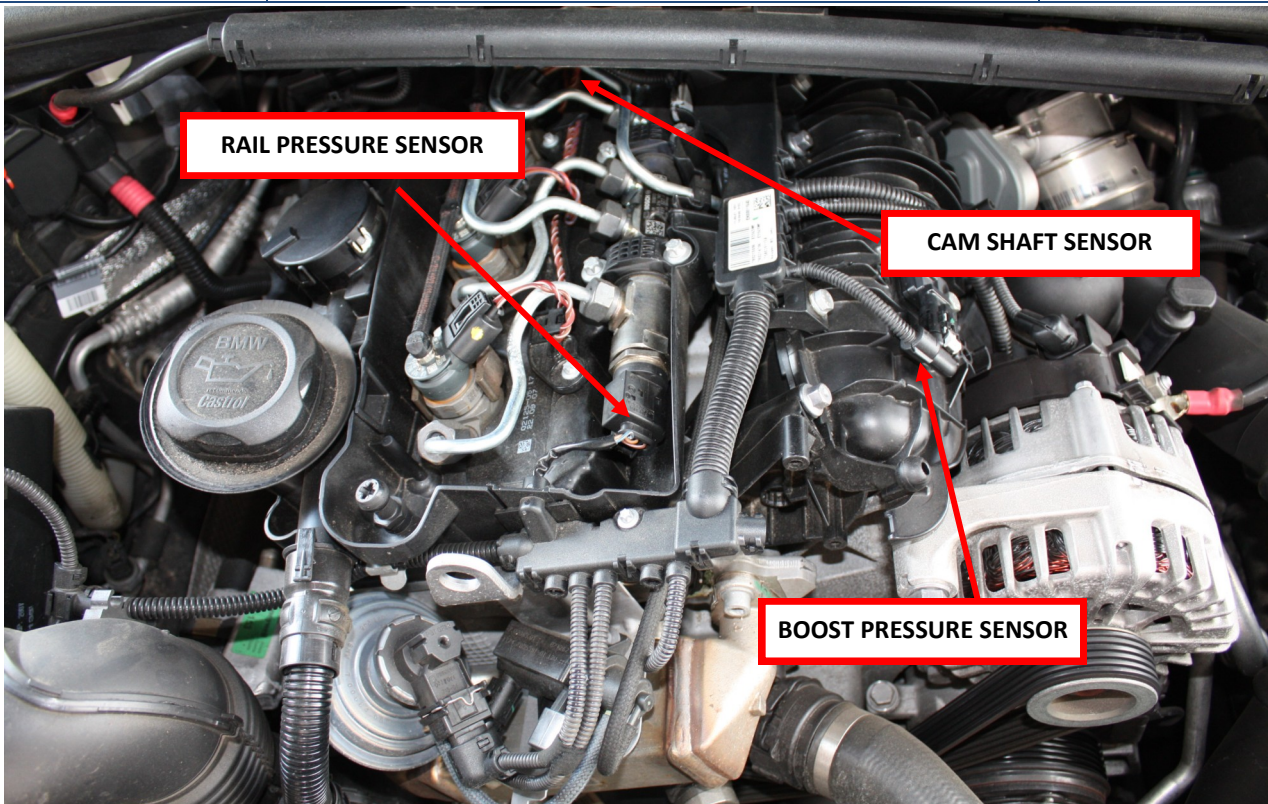

## Overview:

The Chiptuning box is attached to the following points:

- Fuel rail pressure sensor (Seite 3)
- Boost pressure sensor (Seite 4)
- Cam shaft sensor (Seite 5)

## Necessary tools:

- no

## Preparation:

- Move the individual strands of the cable loom to the associated plug connectors
- Put the necessary tool for the side (if needs)
- Put the mounting material to the side



# INSTALLATION MANUAL

BMW 2.0D

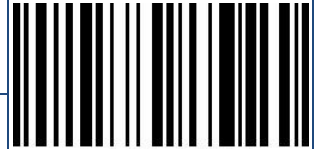

14104707

## Attach at the fuel rail pressure sensor

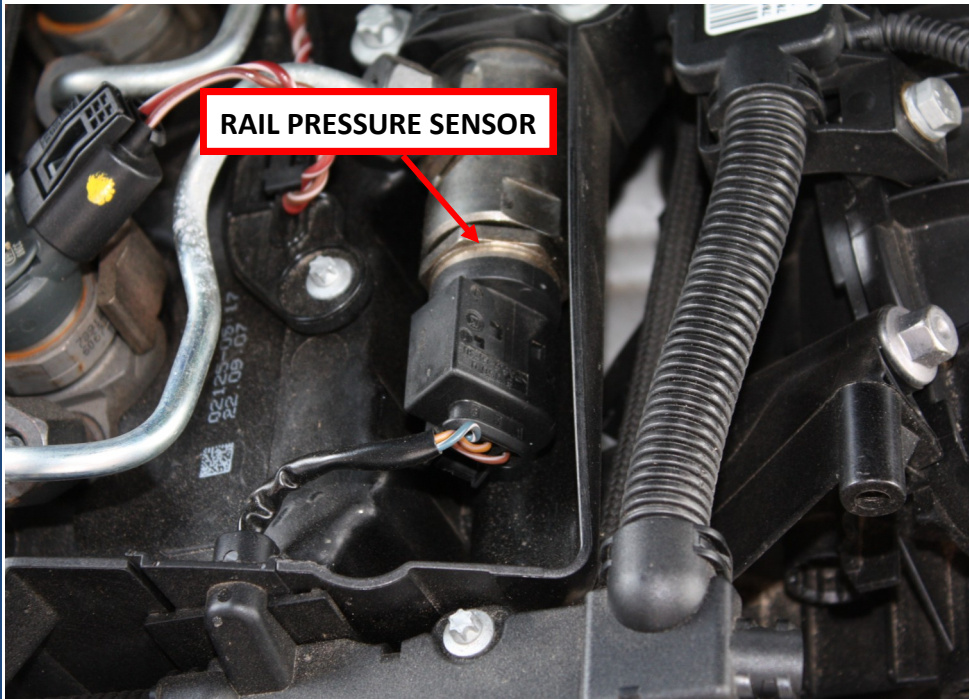

-Disconnect the plug connector of the fuel rail pressure sensor plug from the fuel rail pressure sensor.

-Putting it now between this separate plug connector the appropriate plug of the cable loom provided.

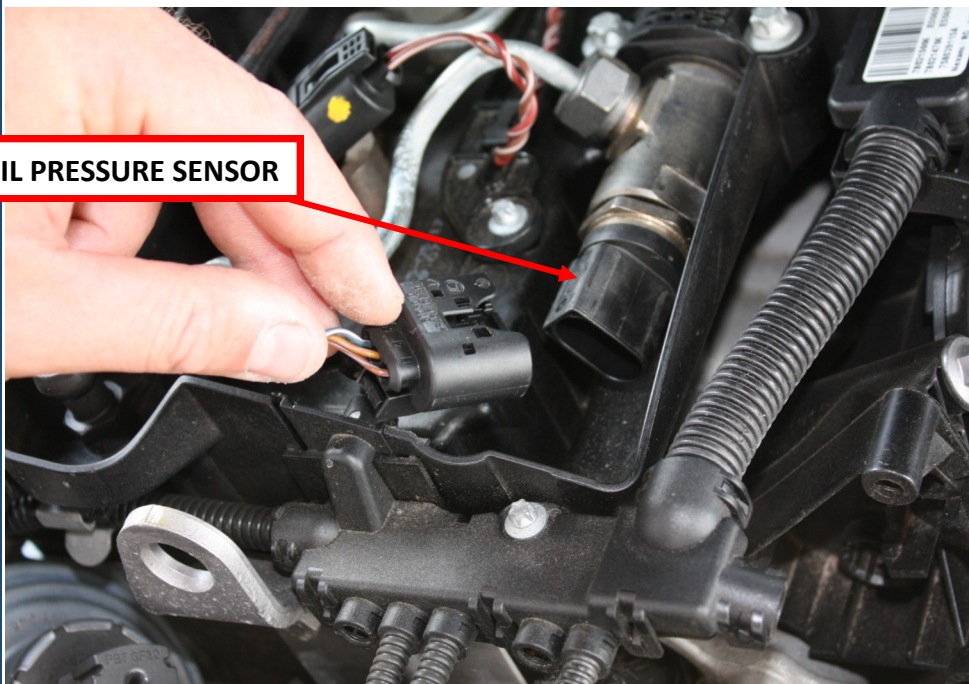

- The appropriate plug of the cable loom provided is fastened now directly to the sensor.



# INSTALLATION MANUAL

BMW 2.0D

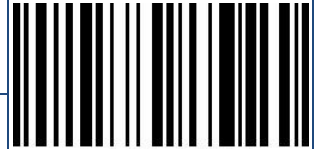

14104707

## Attach at the boost pressure sensor

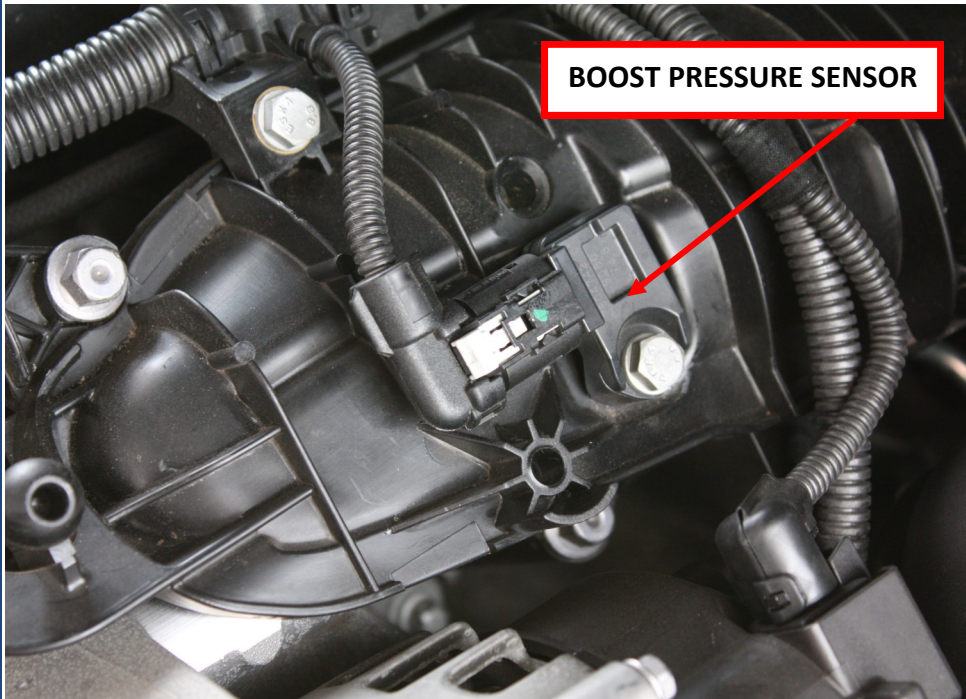

-Disconnect the plug connector of the boost pressure sensor plug from the boost pressure sensor.

-Putting it now between this separate plug connector the appropriate plug of the cable loom provided.



- The appropriate plug of the cable loom provided is fastened now directly to the sensor.

# INSTALLATION MANUAL

BMW 2.0D

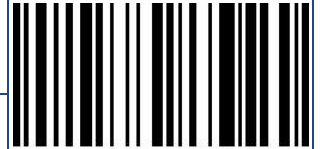

14104707

## Attach at the cam shaft sensor

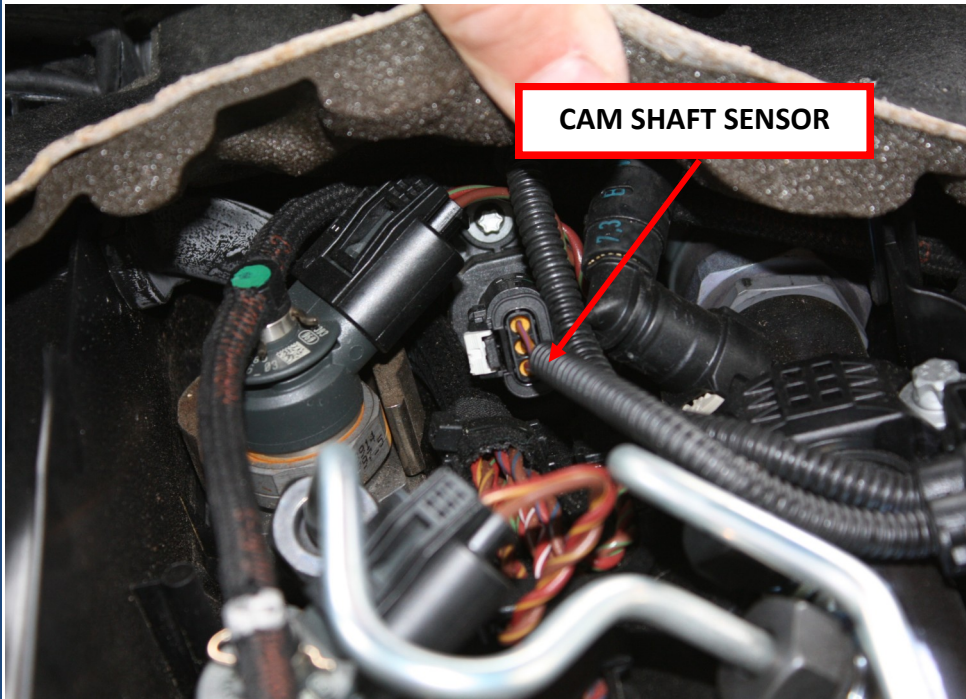

- Disconnect the plug connector of the cam shaft sensor plug from the cam shaft sensor.
- The cam shaft sensor is under the blanket insulator.



- Putting it now between this separate plug connector the appropriate plug of the cable loom provided.
- The appropriate plug of the cable loom provided is fastened now directly to the sensor.



# INSTALLATION MANUAL

BMW 2.0D

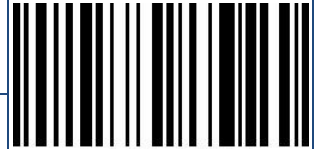

14104707

## Attach the Chiptuning-Box

Attach the Chiptuning-Box

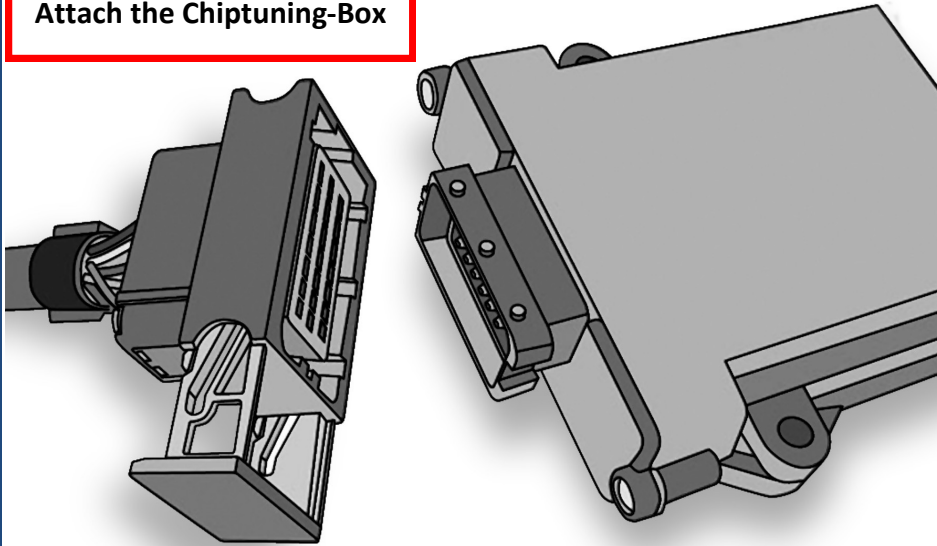

- Moving it the cable toward a suitable location.
- The plugs must engage, so that a safe connection is ensured.
- Fixing it the cable with cable straps
- Finally you connect the Chiptuning box with the new cable loom .